

Installation checklist for Roxtec HD 16 and HD 32

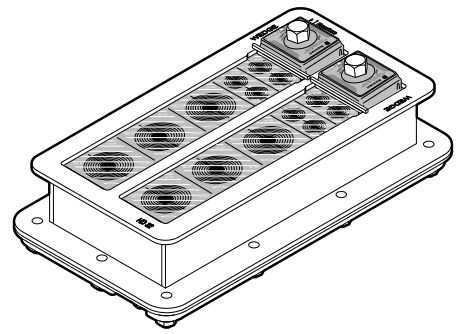

Variants covered by these instructions are:
HD, HD Ex, HD BG, HD BG Ex

Legend



Correct installation



Incorrect installation

Checkpoints HD 16 and HD 32



Check that the product is free from mechanical damages.

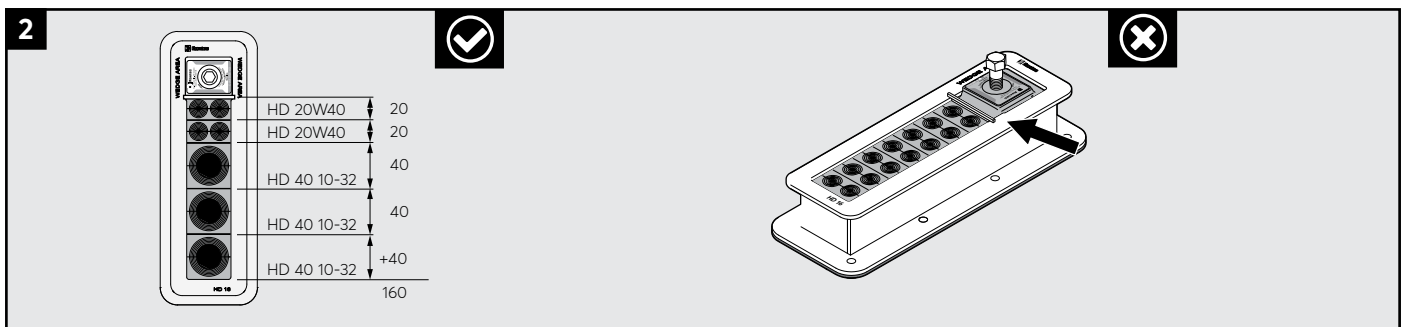

Check that the modules in total correspond to a packing height of 160 mm as the configuration example to the left shows.

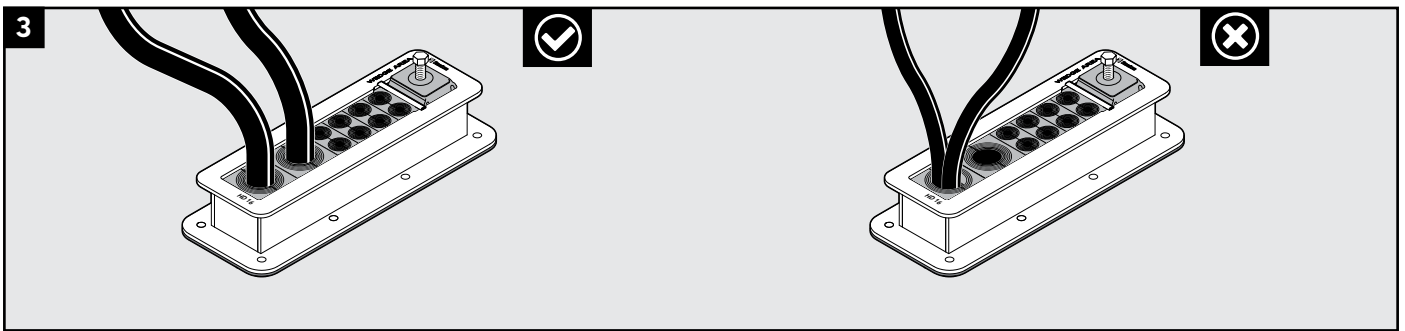

Check that only one cable/pipe passes through each opening in a module.

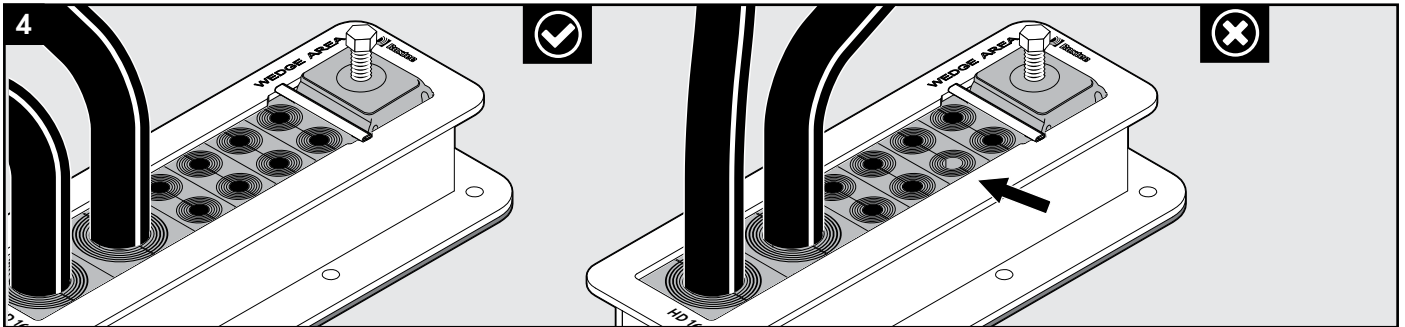

Check that there are no center cores missing.

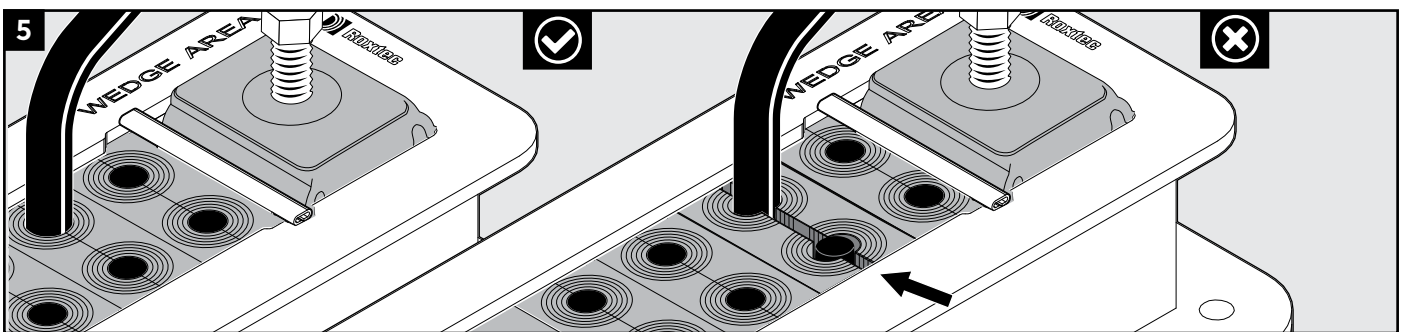

Check that there are no visible gap in the transit after compression.

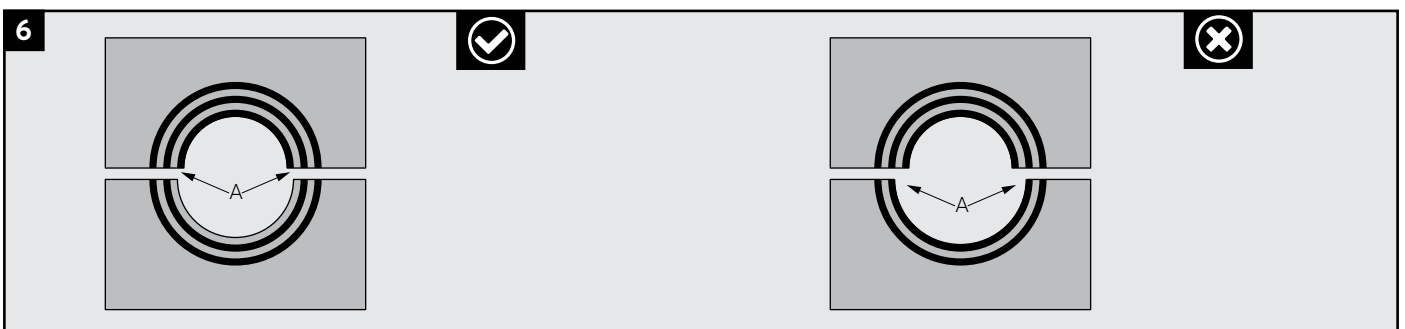

The number of layers may not differ by more than one between the corresponding module halves.

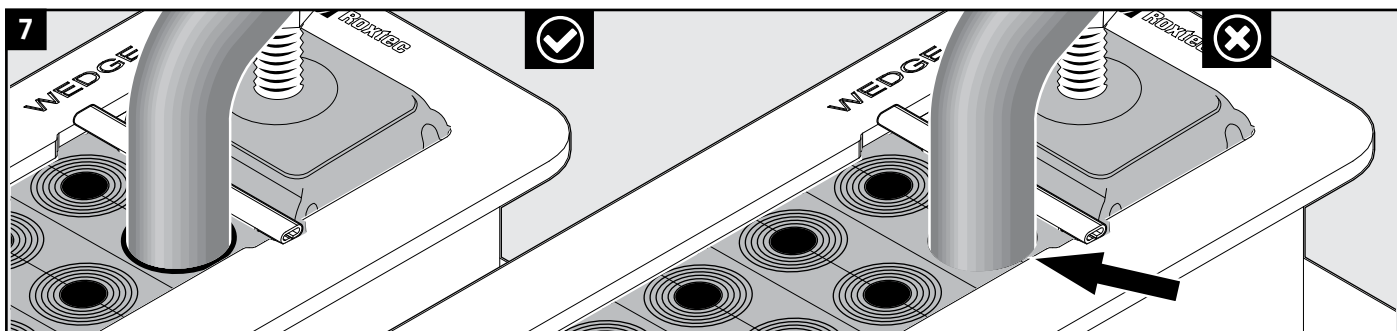

Check that the last layer is not removed for HD standard, HD Ex and HD BG Ex. For HD BG it is allowed to remove the last layer.

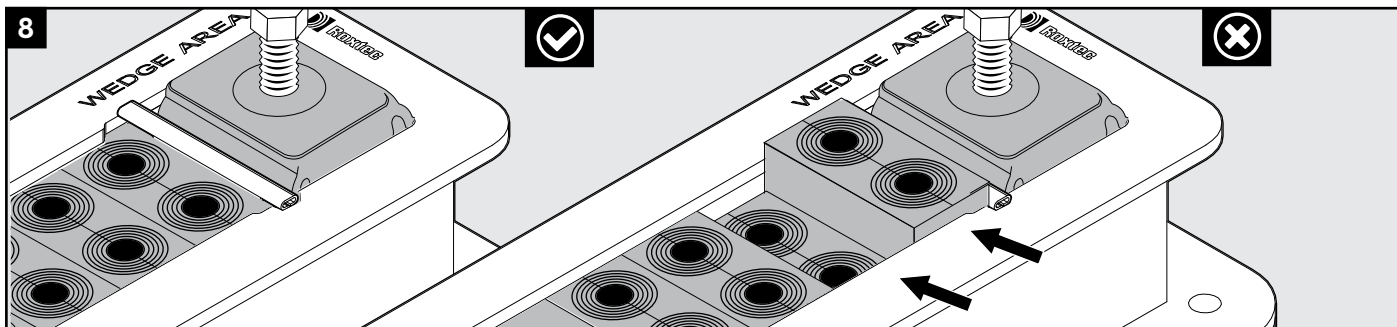

Check that all modules are within the edges of the frame and pushed against the edge.

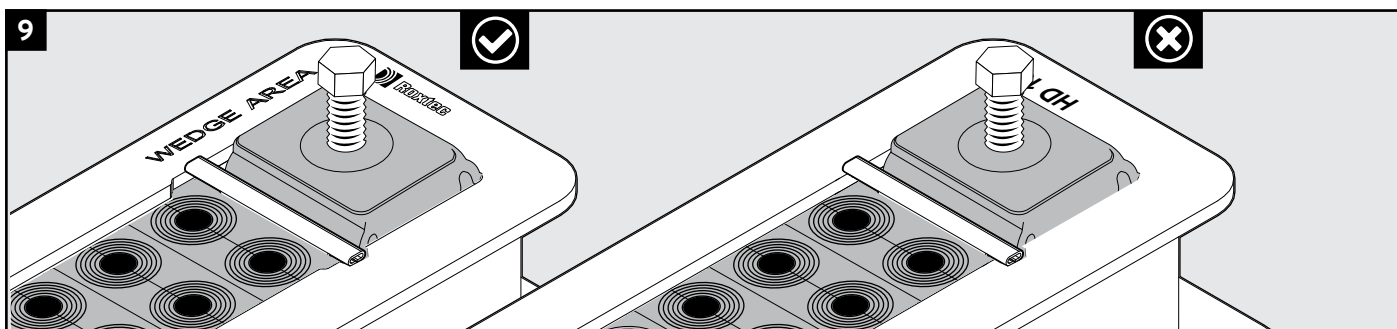

Check that the wedge is located at the correct end of the frame, where the text on the frame says "wedge area".

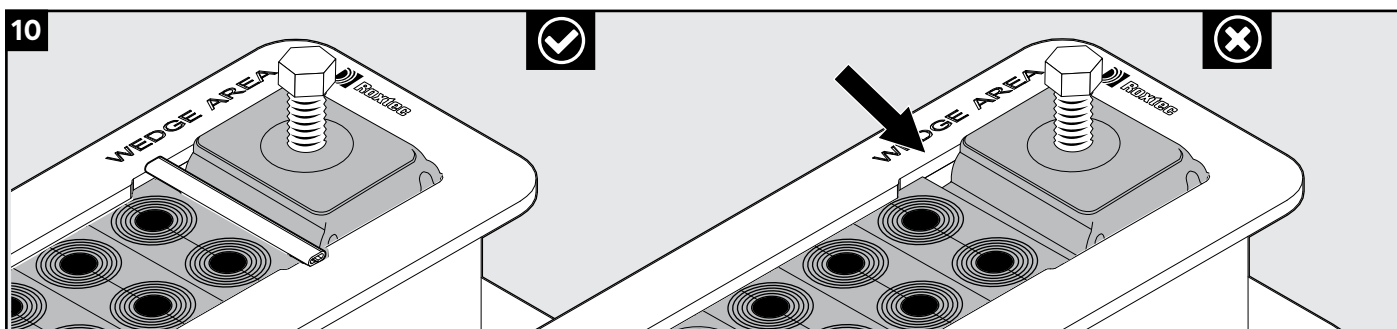

Check that the stayplate is placed under the wedge.

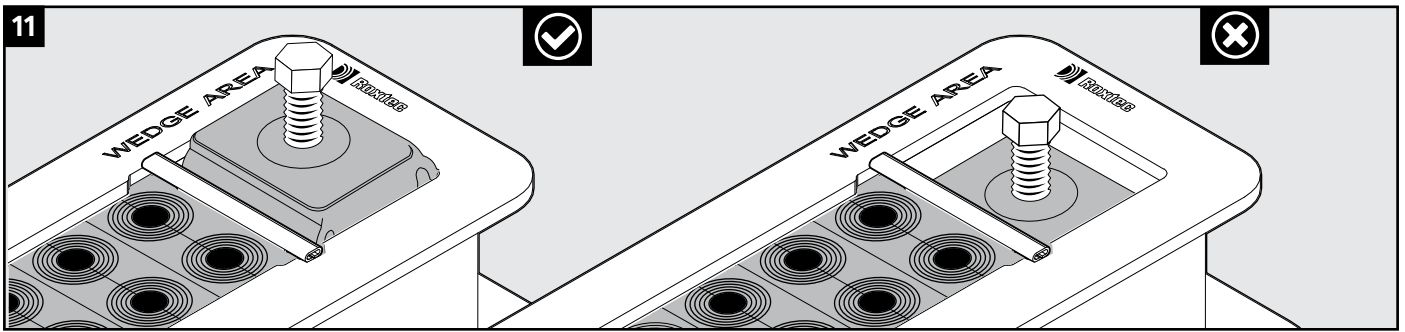

Check that the wedge is correctly centered in the frame.

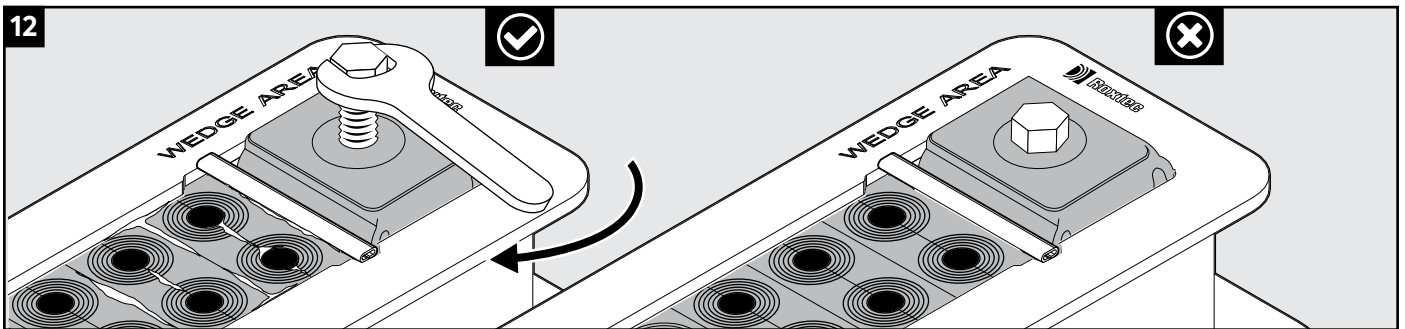

Check the compression. Visible excess lubricant is a sign of good compression. Check that the wedge screw is fully tightened.

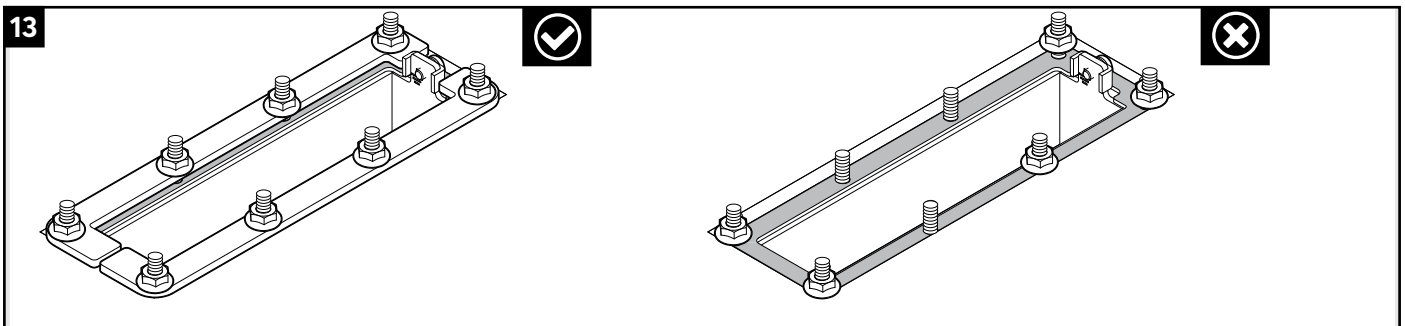

Check that the frame gaskets and counter-frame are mounted correctly and all attachment nuts are used.

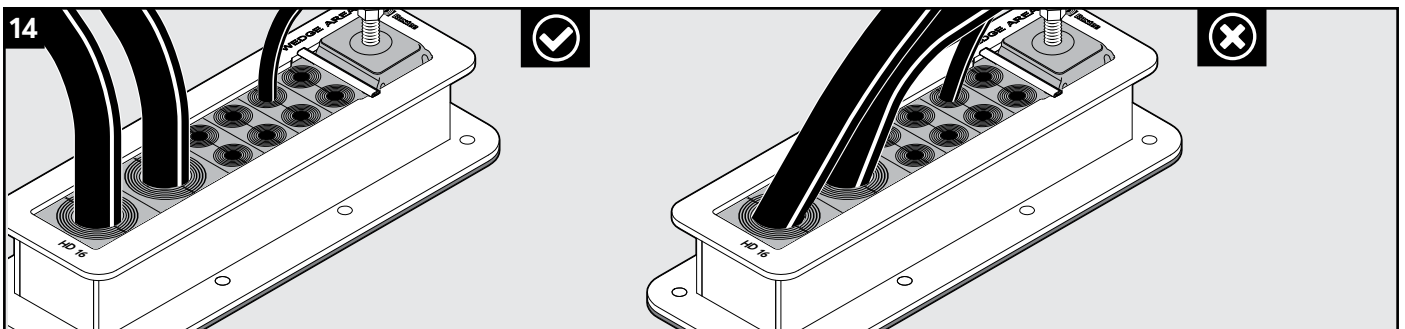

Check that the cables go straight through the frame.

Checkpoints HD 16 Ex and HD 32 Ex

Additional checking in addition to checkpoints under heading HD 16 and HD 32.

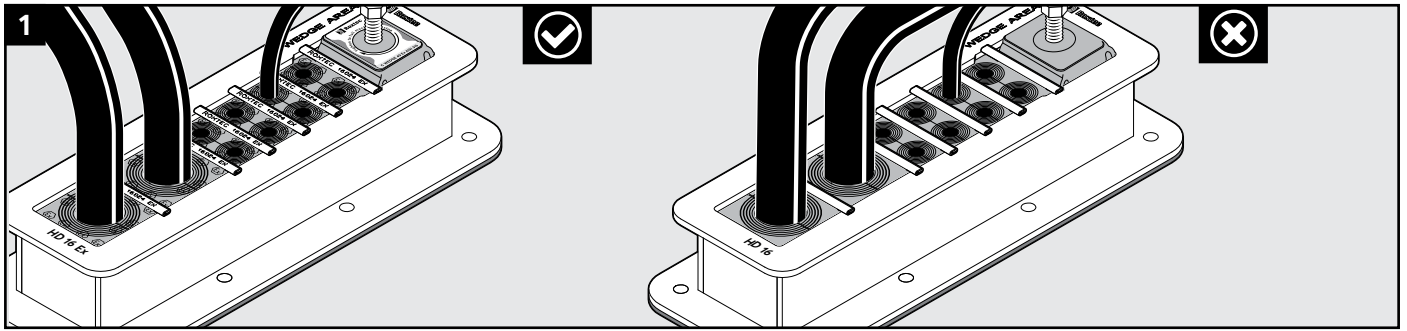

Check that the frame, wedge, stayplate and modules are marked with Ex.

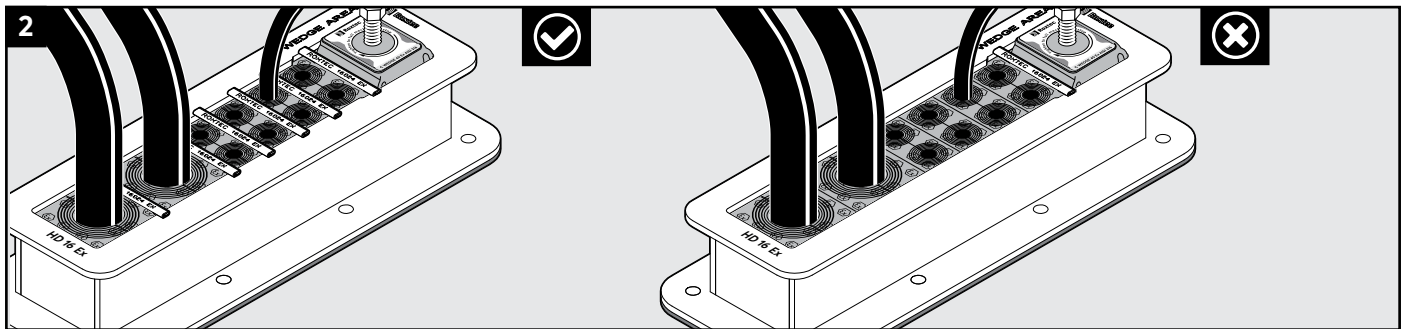

Check that there is a stayplate between each row of modules.

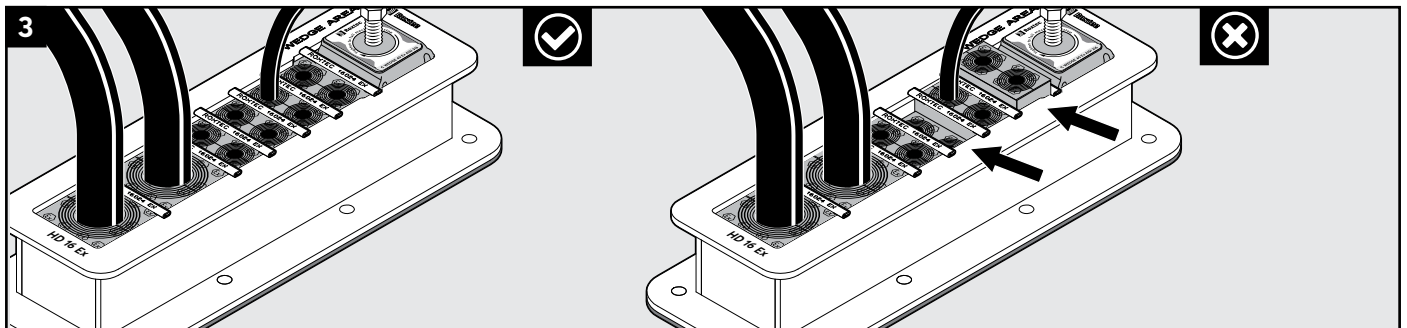

Check that all modules are within the edges of the stayplates.

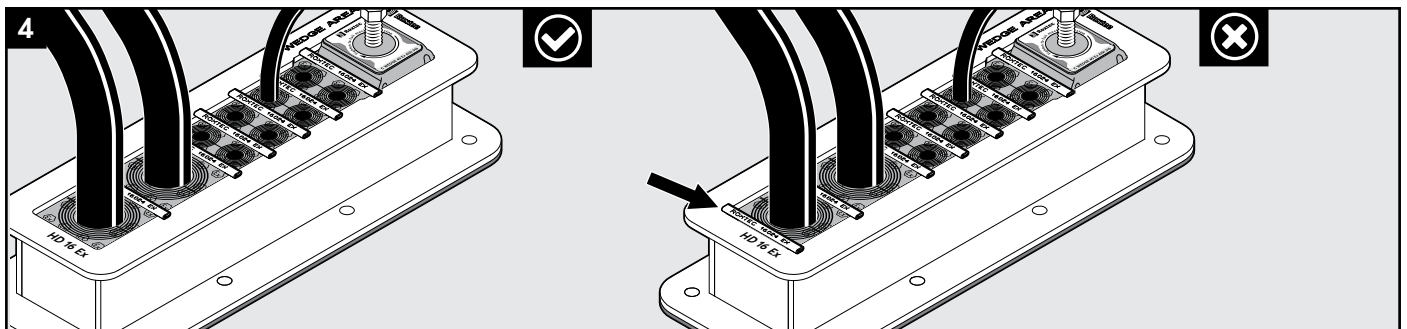

Check that there is no stayplate installed next to the frame.

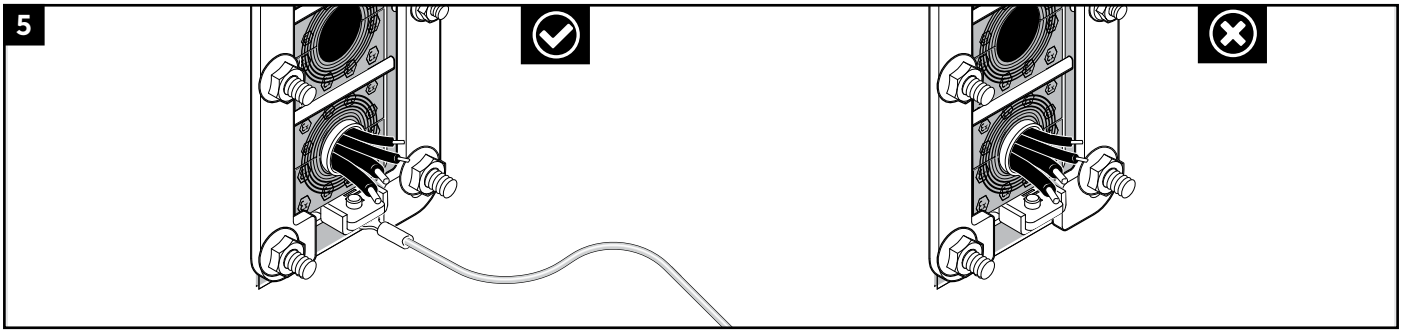

Check that a protective bonding conductor is attached to the frame earthing terminal.

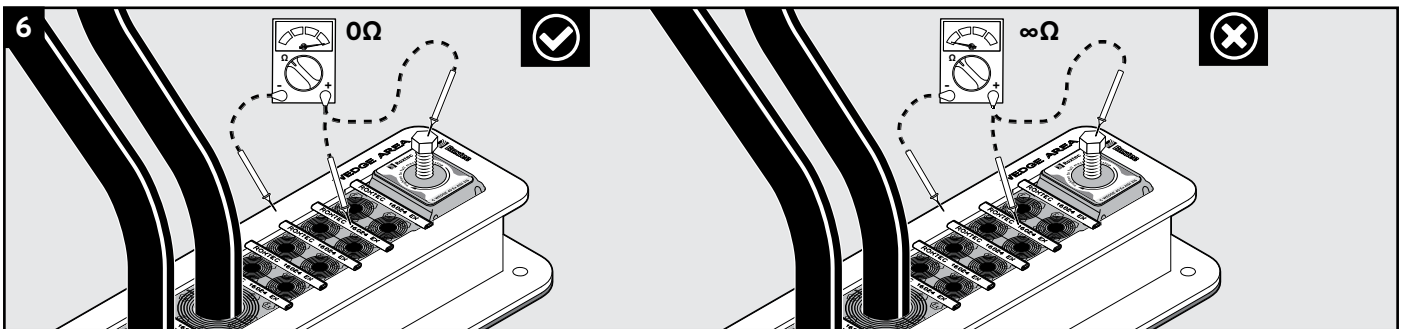

Check for continuity between all stayplates and the frame. Check for continuity between the wedge screw and the frame.



Check that no other corrugated cables than listed in installation instruction or certificates are installed.

Checkpoints HD 16 BG and HD 32 BG

Additional checking in addition to checkpoints under heading HD 16 and HD 32.

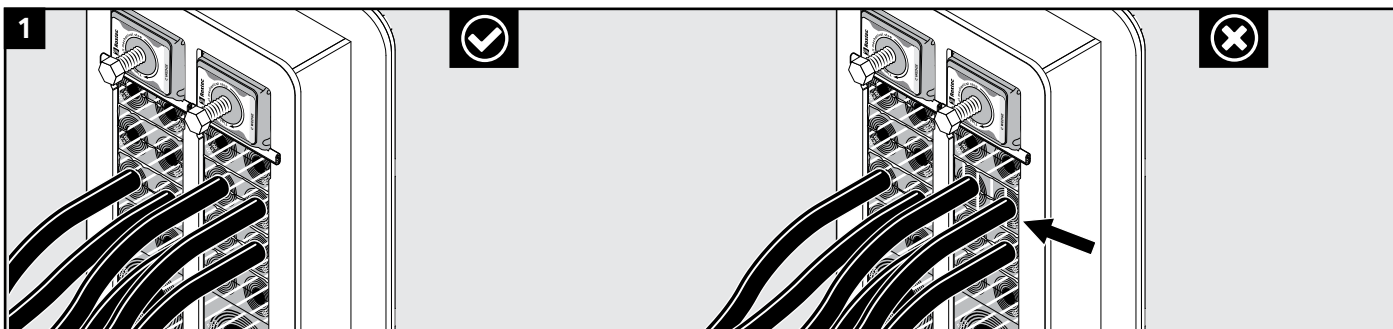

Check that all modules are installed correctly by checking the marking. Diagonal marking on the environmental side and vertical marking on the termination/interior side.

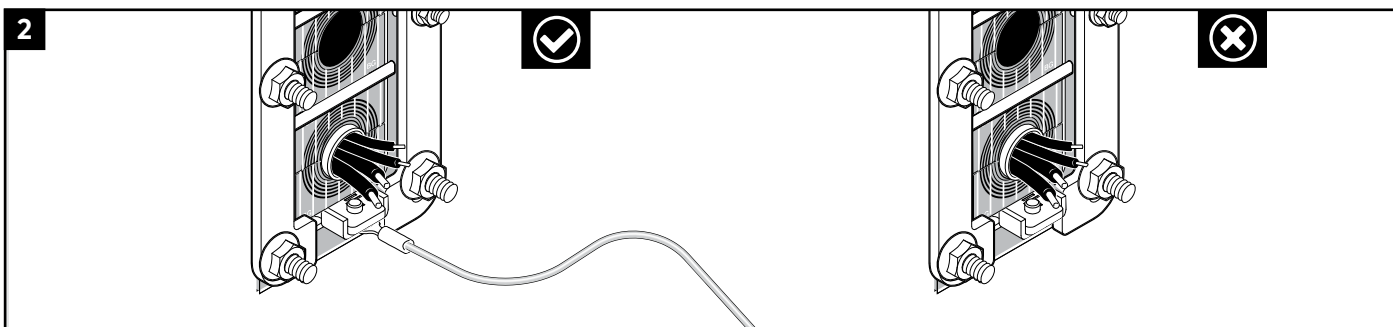

Check that a protective bonding conductor is attached to the frame earthing terminal.

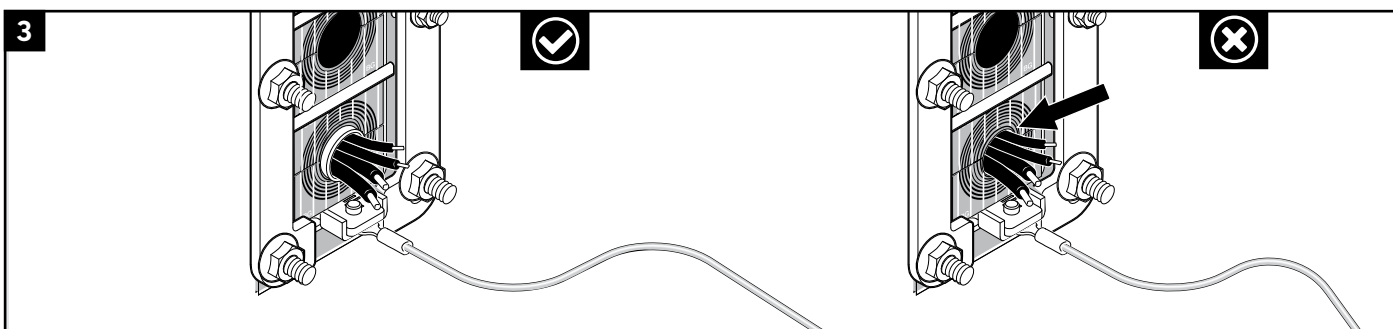

Check that the cable armor is visible outside the module at the termination side.



For installation verification of Roxtec BG™ systems, see document "Verification of contact resistance for Roxtec BG™ solutions".

Checklist HD 16 and HD 32

Project/object:

Date:

Transit name:

Full name:

Frame type:

Company:

Opening:

Signature:

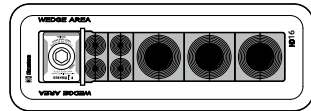
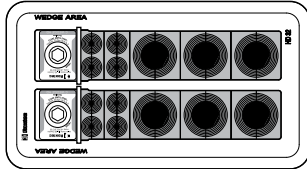

Checkpoint

Activity

OK

Not OK

Checkpoint	Activity	OK	Not OK
1	Check that the product is free from mechanical damages.		
2	Check that the modules in total correspond to a packing height of 160 mm as the configuration example to the left shows.		
3	Check that only one cable/pipe passes through each opening in a module.		
4	Check that there are no center cores missing.		
5	Check that there are no visible gap in the transit after compression.		
6	The number of layers may not differ by more than one between the corresponding module halves.		
7	Check that the last layer is not removed for HD standard, HD Ex and HD BG Ex. For HD BG it is allowed to remove the last layer.		
8	Check that all modules are within the edges of the frame and pushed against the edge.		
9	Check that the wedge is located at the correct end of the frame, where the text on the frame says "wedge area".		
10	Check that the stayplate is placed under the wedge.		
11	Check that the wedge is correctly centered in the frame.		
12	Check the compression. Visible excess lubricant is a sign of good compression. Check that the wedge screw is fully tightened.		
13	Check that the frame gaskets and counter-frame are mounted correctly and all attachment nuts are used.		
14	Check that the cables go straight through the frame.		

Note

Checklist HD 16 Ex and HD 32 Ex

Additional checking in addition to checkpoints under heading HD 16 and HD 32.

Project/object:

Date:

Transit name:

Full name:

Frame type:

Company:

Opening:

Signature:

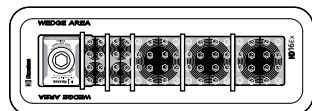
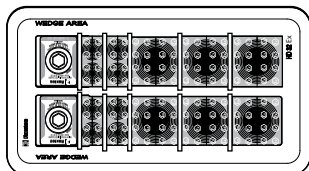

Checkpoint

Activity

OK

Not OK

Checkpoint	Activity	OK	Not OK
1	Check that the frame, wedge, stayplate and modules are marked with Ex.		
2	Check that there is a stayplate between each row of modules.		
3	Check that all modules are within the edges of the stayplates.		
4	Check that there is no stayplate installed next to the frame.		
5	Check that a protective bonding conductor is attached to the frame earthing terminal.		
6	Check for continuity between all stayplates and the frame. Check for continuity between the wedge screw and the frame.		
7	Check that no other corrugated cables than listed in installation instructions or certificates are installed.		

Note

Checklist HD 16 BG and HD 32 BG

Additional checking in addition to checkpoints under heading HD 16 and HD 32.

Project/object:

Date:

Transit name:

Full name:

Frame type:

Company:

Opening:

Signature:

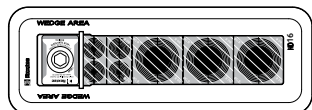
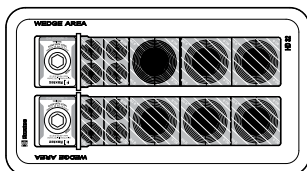

Checkpoint

Activity

OK

Not OK

Checkpoint	Activity	OK	Not OK
1	Check that all modules are installed correctly by checking the marking. Diagonal marking on the environmental side and vertical marking on the termination/interior side.		
2	Check that a protective bonding conductor is attached to the frame earthing terminal.		
3	Check that the cable armor is visible outside the module at the termination side.		
4	For installation verification of Roxtec BG™ systems, see document "Verification of contact resistance for Roxtec BG™ solutions".		

Note

Important

These lists of installation checkpoints can be used to visually assess a Roxtec cable/pipe transit sealing system installation. The check is performed to visually verify the correctness of an installation, not a commissioning or functional inspection. The verifications shall be performed and evaluated with the understanding that not all installation errors can be visually detected, even if it is a great help in the quality assurance work. The installation check is limited to those areas and sections of the installation to which reasonable access is both available and permitted at the date of checking. The scope of these installation checkpoints is limited to the transit (frame, modules, stayplates and wedge). Consequently, it does not cover the attachment of the transit to the structure in question, e.g. insulation required, nor the correctness, quality or routing of cables/pipes. If possible, perform the installation check from both sides of the transit.

Disclaimer

*The Roxtec cable entry sealing system ("the Roxtec system") is a modular-based system of sealing products consisting of different components. Each and every one of the components is necessary for the best performance of the Roxtec system. The Roxtec system has been certified to resist a number of different hazards. Any such certification, and the ability of the Roxtec system to resist such hazards, is dependent on all components that are installed as a part of the Roxtec system. Thus, the certification is not valid and does not apply unless all components installed as part of the Roxtec system are manufactured by or under license from Roxtec ("authorized manufacturer"). Roxtec gives no performance guarantee with respect to the Roxtec system, unless (I) all components installed as part of the Roxtec system are manufactured by an authorized manufacturer and (II) the purchaser is in compliance with (a), and (b), below.

(a) During storage, the Roxtec system or part thereof, shall be kept indoors in its original packaging at room temperature.
 (b) Installation shall be carried out in accordance with Roxtec installation instructions in effect from time to time.

The product information provided by Roxtec does not release the purchaser of the Roxtec system, or part thereof, from the obligation to independently determine the suitability of the products for the intended process, installation and/or use.

Roxtec gives no guarantee for the Roxtec system or any part thereof and assumes no liability for any loss or damage whatsoever, whether direct, indirect, consequential, loss of profit or otherwise, occurred or caused by the Roxtec systems or installations containing components not manufactured by an authorized manufacturer and/or occurred or caused by the use of the Roxtec system in a manner or for an application other than for which the Roxtec system was designed or intended.

Roxtec expressly excludes any implied warranties of merchantability and fitness for a particular purpose and all other express or implied representations and warranties provided by statute or common law. User determines suitability of the Roxtec system for intended use and assumes all risk and liability in connection therewith. In no event shall Roxtec be liable for indirect, consequential, punitive, special, exemplary or incidental damages or losses.*



Roxtec International AB
 Box 540, 371 23 Karlskrona, SWEDEN
 +46 455 36 67 00, info@roxtec.com
 www.roxtec.com